

KUBB MONO PLANTER BY BELLITALIA

OE-BI-3043

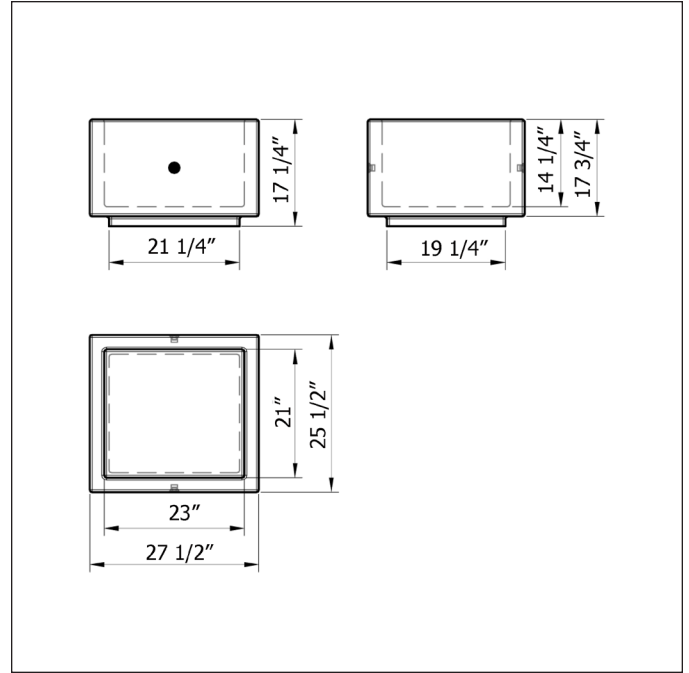

The Kubb Mono is a monolithic planter with rectangular section, fitted with a water reserve system to guarantee the soil the proper humidity level, avoiding the dispersion of internal water.

COLLECTION

Kubb

MATERIALS

The planter is manufactured using reconstituted natural marble stones (white Carrara, black ebony, botticino, porphyry, red Verona, venezolano, yellow more, green alps) or white granite conglomerate. The planter is reinforced and embedded with bushings that permit its lifting, and that are covered with a Bellitalia plate after the placement. All surfaces are sandblasted, except for the top surface that can be polished, to give the product a shiny effect, or bush-hammered, for a rough appearance. Surfaces are then covered with a transparent anti-decay coating, or an anti-graffiti product. All edges are rounded or made blunt.

INSTALLATION

Place the planter on the flooring.

MAINTENANCE

The stone conglomerate is an extremely durable material that requires minimal maintenance. This purely consists of the treatment of the surface with very fine abrasive paper and in the re-application of one or more coats of the acrylic protective varnish. In case of accidental chipping of the artifacts made of conglomerate, BELLITALIA® provides a repair kit consisting of a bi-component material the same as the original. To apply simply clean the chipped area, removing any dust or deposits, and then apply the past component. Once the drying is completed, it is sufficient to apply a coat of transparent acrylic anti-decay varnish.

MALIK
outdoor

malikoutdoor.com
888.550.4398